



Oaken

Combining innovative technology and environmentally conscious design, the Oaken is at the forefront of sustainability in the field of street lighting. By optimising energy efficiency and prioritising sustainable materials, the Oaken demonstrates a commitment to minimising its carbon footprint throughout its entire lifecycle.



WHY?

TRT (Thorlux Road and Tunnel) and the wider FW Thorpe Group specialise in designing and manufacturing professional lighting systems that deliver technically advanced solutions having a strong emphasis on efficiency, environmental sustainability and low cost of ownership.

TRT's vision for its latest generation products is to take the focus on sustainability to the highest achievable level; both for the product during its manufacturing stage and for its through life operation.

Our aim was to produce the world's most sustainable street light.

We intended to make this product mainstream, not just for niche applications but to make its impact significant by revolutionising the street and exterior lighting market, providing groundbreaking levels of sustainability that we can all be proud to talk about.

HOW?

The Oaken has been engineered to redefine the benchmarks of sustainability, starting with its construction techniques. Crafted with a commitment to environmental responsibility, each and every component has been carefully selected to ensure minimal ecological impact throughout its lifecycle.

Engineered to minimise the environmental impact.



EUROPEAN OAK HOUSING

- Sourced from PEFC certified European forests
- Crafted from strips of laminate wood, utilising European oak that might otherwise be overlooked for traditional furniture applications
- Highly durable material that can withstand exposure to extreme weather conditions, and, will achieve a life in excess of 20 years



CMS SOCKET

- Control light levels to enhance energy efficiency and cost saving



100% POST-INDUSTRIAL RECYCLED POLYCARBONATE GEAR ENCLOSURE

- IP66 rating provides high degree of protection and durability
- Using recycled material made from industrial waste
- Made in Britain



SUPER EFFICIENT DRIVER

- Circuit optimisation with up to 92% efficiency
- Made in the EU

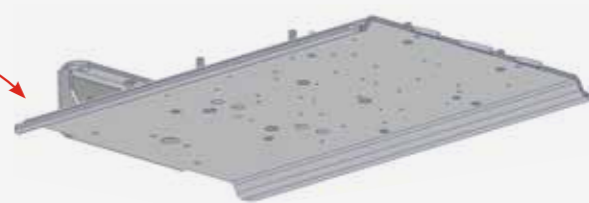

GEAR TRAY MADE FROM >90% RECYCLED ALUMINIUM SHEET

- Less heating processes and no mining
- Unpainted, simplifying the recycling process
- Made in EU



>90% RECYCLED ALUMINIUM MOUNTING POST

- Less heating processes and no mining
- Made in EU

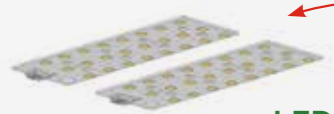

LED MODULE

- Up to 191.7 luminaire lumens per circuit watt
- Made in EU

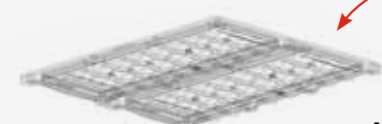

HIGHLY EFFICIENT PMMA & PC LENSES

- Impact resistance rating of IK07



LUMI-LINQ SENSOR

- Monitors energy usage
- Daily energy and carbon saving reporting
- Made in Britain

CIRCULAR DESIGN

What truly sets the Oaken apart is its dedication to circular design principles. Each component is designed for disassembly and recyclability, facilitating the recycling and repurposing of materials at the end of its life.

The TM66 Assured Product Verification Scheme is an innovative initiative developed and fulfilled by the Lighting Industry Association (LIA) and endorsed by CIBSE (Chartered Institution of Building Services Engineers). A TM66 score demonstrates a product's performance in the context of a Circular Economy. The Oaken has an 'excellent' score of 3.1 – the highest published score for any luminaire under the esteemed LIA/CIBSE certification scheme TSD-012, showcasing the lanterns excellent product circularity.



Angular design to disperse water, promoting product longevity

Sustainably harvested European oak sourced from PEFC certified forest

Unpainted aluminium gear tray, simplifying the recycling process

No powder coating, simplifying the recycling process

97%
reduction in 'Cradle to Gate' embodied carbon*

50%
reduction in embodied carbon in the complete luminaire**

Excellent TM66 circularity score of **3.1**

Highly recyclable components at end of life

EMBODIED CARBON

The embodied carbon of the Oaken has been calculated using TM65 methodology. In comparison to the TRT Aspect Mini luminaire the Oaken has:



* Compared to aluminium cast alloy body baseline
** Aspect Mini has 66kg CO₂e, Oaken has 34kg CO₂e

WHERE



Certified by DarkSky.org

TRT is committed to reducing obtrusive light and light trespass in order to protect the night sky from light pollution.

The preservation of the dark sky is critical not only for the well-being of people and wildlife, but also for scientific and astronomical purposes.

The Oaken has achieved International Dark-Sky Association approval. It is compliant when using a colour temperature of 3000K or below at 0° tilt as this results in no upward light.



Residential Roads



Car Parks



Footpaths



Cycleways



Pedestrianised Areas

IMPRESSIVE PERFORMANCE

The Oaken exemplifies the supreme performance that is expected of TRT luminaires with an efficiency of up to 191.7 luminaire lumens per circuit watt: minimising energy consumption while maximising light output. The LEDs are not only highly efficient but also boast a 100,000 hour rated life, reducing the need for frequent replacements and contributing to a substantial decrease in electronic waste.

The latest generation LED driver optimises Oaken's power efficiency through its incorporation of two possible DC current output channels. These channels allow the product's chosen power rating to be selected during manufacture, from two options that more closely match optimum conditions. Driver efficiency will therefore be closer to the maximum of 92% as opposed to less optimal drivers, having only one channel option, achieving only 85%.

INTELLIGENT CONTROL

Massive energy savings and extended maintenance cycles are possible by combining programmable presence detection and light sensing with LED luminaires. Savings by the installation of automatic lighting control systems often exceed 70%. From simple factory-set dimming to full wireless control the Oaken is available with numerous connectivity options and can be specified with 7-pin NEMA and Zhaga Book 18 sockets.



POWERSET NFC

The Oaken is also available with the TRT PowerSet integral power output selection device, enabling on site adjustment. Employing an NFC remote control, you have the ability to scan a QR code specifying your preferred wattage. Direct the remote towards the wooden housing, and the radio signals transmit through with ease, negating the need to open the lantern.



THE ROAD TO NET-ZERO

TRT, as part of the FW Thorpe Group of companies, is committed to minimising the environmental impact of its activities across all operations.

The FW Thorpe Group of companies has been officially recognised as being carbon neutral, with systems of reduction, measurement and certified offsetting in place, since 2012. Third party assessment provides independent assurance of the Group's long-standing commitment to sustainability across all of its operations worldwide. Being carbon neutral means that FW Thorpe Plc offsets the carbon dioxide emissions it generates (scopes 1 and 2 of the Greenhouse Gas Protocol) by its business activities.

FW Thorpe Plc is a carbon neutral company through a combination of measures. Company-wide initiatives such as energy use minimisation, self-generation of renewable energy through solar photovoltaic (PV) units, and procurement of renewable energy have reduced the Group's carbon footprint, whilst trees in the Group's award-winning carbon offsetting afforestation project absorb the remaining carbon dioxide produced.

In 2022, FW Thorpe initiated a robust data collection process to calculate its full carbon footprint, extended to include upstream and downstream activities – for example those throughout its supplier and customer relationships. The Group's carbon emission reduction plan is aligned with the Paris Agreement 1.5°C scenario (reactive) and its full Scope 1, 2 and 3 emissions for the 2021 base year, 2022, and the previous financial year 2023 have been calculated.

The goal is ultimately to reach net-zero in 2040, 10 years before the UK's target for achieving net-zero greenhouse gas (GHG) emissions by 2050.

EMISSION REDUCTION TARGETS

FW Thorpe has set and submitted the following Science aligned targets for validation by the Science Based Targets Initiative:

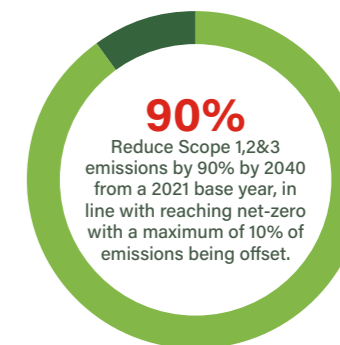
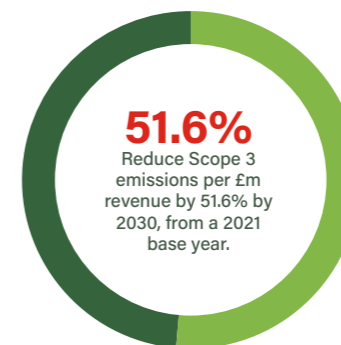

CARBON OFFSETTING

In 2009, FW Thorpe Plc purchased 215 acres of farmland in Wales. To date, 179,412 trees have been planted for carbon sequestration. Based on the Group's calculated emissions, it has been confirmed that enough trees have been planted for FW Thorpe Plc to have been carbon neutral since 2012.

The carbon capture tree-planting scheme (quality-assured by the government-backed Woodland Carbon Code) is independently certified to ISO 14064-3 and ISO 14065 standards. The Woodland Carbon Code is an independent standard, devised by a group led by the UK Forestry Commission, to certify that woodland creation projects can accurately measure how much carbon is captured and stored.

FW Thorpe has completed its woodland creation project in Devauden, Wales and has recently purchased a further 195 acres of land in Herefordshire. The land has significant potential for connecting existing woodlands for biodiversity and landscape enhancement and the transition from grazing sheep to woodland creation will have little to no impact on food security.

RENEWABLE ELECTRICITY GENERATION

In line with the FW Thorpe carbon reduction initiatives, TRT has installed solar photovoltaic (PV) units on the roof of its manufacturing site to harness and utilise as much natural energy as possible. The power generated by the PV arrays is distributed across the business, providing power to the plant and machinery whilst also charging the TRT fleet of hybrid and electric vehicles.

In addition to the power generated by the PV arrays, all purchased electricity now comes from renewable sources thus deeming 100% of TRT's electricity consumption to be from renewable energy.

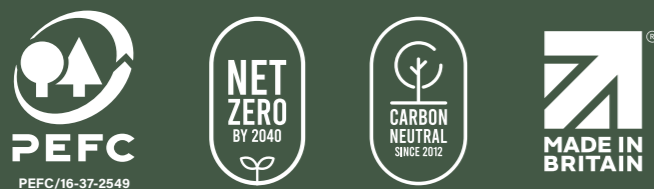

Q&As

WHY WOOD?

- ✓ Wood has less embodied carbon (CO₂e/kg) and requires less embodied energy compared to aluminium castings. Since wood is a renewable resource and requires less energy-intensive processes to be transformed into a usable material, it contributes less to the overall embodied carbon footprint.
- ✓ Trees can be regrown through sustainable harvesting programmes. Responsible forestry practices involve replanting trees and managing the harvesting process to ensure a continuous and sustainable supply of wood. Participating in sustainable harvesting programmes helps maintain the balance between consumption and regeneration, ensuring that the use of wood does not deplete forests irreversibly.
- ✓ Proven longevity and durability which not only reduce the frequency of replacements but also contribute to a lower environmental impact over the product's life cycle.

WHY SPECIFICALLY EUROPEAN OAK?

- ✓ European oak is an extremely durable hardwood that will achieve in excess of a 20-year life, reducing the frequency of replacements and minimising waste.
- ✓ European oak is sustainably harvested. Sustainable harvesting practices involve careful consideration of the environmental impact, ensuring that the rate of extraction does not exceed the rate of regeneration. This approach helps maintain the health and biodiversity of forests while providing a continuous supply of wood.
- ✓ The location of this wood in comparison to the sourcing of aluminium, ensures carbon emissions generated by transportation and shipping are minimised.

Wood is a more environmentally friendly material to use and helps push TRT Lighting towards its net-zero goal.

DOES THIS CONTRIBUTE TO DEFORESTATION?

No, the European oak forests are sustainably managed.

The European oak forests are monitored and regulated by the Programme for the Endorsement of Forest Certification (PEFC). PEFC is an international non-profit organisation that promotes sustainable forest management through certification. The fact that the forests are regulated by PEFC provides assurance that the harvesting of European oak is done in accordance with strict environmental and social standards. This certification helps to prevent deforestation and supports responsible forestry practices.

FW Thorpe Group have planted more than **175,000 trees** in Cwm Fagor forest since 2009 and will continue this tree planting program from 2024 onwards at Brook Farm.

Image: FW Thorpe Group Carbon Offsetting Project, Devauden

WILL THE WOOD WARP?

Yes, but within limitations that do not affect the integrity of the product.

The wood used in assembling the structure will be stable and resistant to warping or twisting due to the lamination of kiln-dried oak planks. This stability is achieved through thoughtful design and the choice of wood type and drying process. While the wood may absorb some water and expand slightly, our patent pending fixing arrangement (more than just fixing) accommodates this expansion. Importantly, the functionality and safety of the sensitive electronic control gear are not dependent on the wood's integrity. Even if the wood degrades, only the appearance of the luminaire is affected, ensuring that function and safety are maintained.

Our patent pending fixing arrangement will compensate for any expansion within the wood.

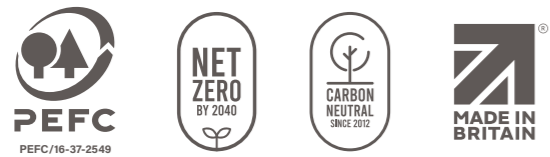

WILL THE WOOD CATCH FIRE?

No, the wood has been 650°C and 850°C hot-wire tested and is fully compliant with the requirements of glow-wire. Hardwood is less prone to ignite easily as it has a higher ignition temperature compared to softwood.

With a flat, smooth surface, the Oaken housing has no small, easily ignitable particles. Additionally, a protective char layer forms when hardwood is exposed to fire which slows down the combustion process.



WHAT IS THE WOOD'S PROJECTED LIFETIME?

European oak has a project lifetime in excess of 20 years.

The wood will naturally take on a silverish hue as it ages. Over time micro fissures in the wood will also appear, but none of these changes will affect product function or safety.

As the natural movement of wood caused by moisture content has been considered, there are no issues in the Oaken being used in coastal applications.

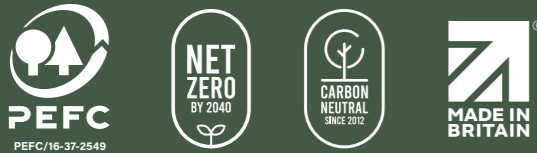

ARE WASTE STREAMS CONTROLLED?

Yes.

The waste wood, whether that be from the initial manufacturing or end of life stage, can be used for biomass briquette or pellet production.

IS THE LANTERN RECYCLABLE?

Yes.

At the end-of-life the wood taken from the Oaken is graded, and based on its grade, it is recycled to produce either biofuel or fibreboard (the recycling process is unaffected by the wood adhesive). The polycarbonate gear tray and aluminium components are also highly recyclable.

DOES WOOD ADHESIVE AFFECT END OF LIFE RECYCLABILITY?

No.

Biomass fuel and fibreboard products can still be manufactured from the wood.





TECHNICAL

ELECTRICAL CHARACTERISTICS	Oaken 12	Oaken 24	Oaken 48
System Power	5-30W	5-30W	30-60W
LED CCT	PC-Amber*, 2700K, 3000K or 4000K	2700K, 3000K or 4000K	
LED CRI	>70 (*>55)	>70	
Lumen Output	Up to 4,633lm	Up to 5,568lm	Up to 11,198lm
Lumen Maintenance	Projected L90 after 100,000 hours		
Driver Current	95-800mA	68-630mA	308-626mA
Driver Output	Constant current (with AM dimming)		
Power Factor (Full Load/Half Load)	0.95/0.90		
Driver Efficiency (230V, 50Hz, Full Load)	91%		92%
Operational Voltage	220-240VAC rms		
Operating Frequency	50/60Hz		
Inrush Current (Apk/50%-µS)	25A/236µS		32A/355µS
Running Current (Max)	0.13A		0.25A
Surge Protection (COM/DIF)	10kV/6kV		
Lighting Controls Options	Lumi-LinQ, NEMA 7, Zhaga Book 18 (SR) socket (top and bottom) and PND		
Dimming Protocols	DALI		

MECHANICAL CHARACTERISTICS

Housing Material	European oak and 5251 H22 certified recycled aluminium
Lens Material	PMMA and polycarbonate options
Housing Finish	Natural
Ingress Protection Rating	IP66
Weight	2.5-4.2kg (12 & 24 LED Versions) 2.9-5.1kg (48 LED Version)
Wind Area	0.021m ² (12 & 24 LED Versions) 0.035m ² (48 LED Version)
Impact Resistance Rating	IK10 (body)/IK07 (lens)
Mounting Methods	Post top 76mm or side entry 42mm
Mounting Inclination	Post top: 0° or +5° Side entry: 0° or -5°

ACCESSORIES

Front/Rear Shield (12 & 24 LED Versions)	83KIT73150
Front/Rear Shield (48 LED Version)	83KIT73151
Side Shield (12, 24 & 48 LED Versions without Lumi-LinQ)	83KIT73152
Side Shield (12 & 24 LED Versions with Lumi-LinQ)	83KIT73186
Side Shield (48 LED Version with Lumi-LinQ)	83KIT73187
35/18 Lux NEMA Cell	66PC1489
20/20 Lux Zhaga Book 18 Cell	66PC1562

OAKEN 12 & 24

Dimensions displayed in millimetres (mm)

Minimum order quantities apply. Please contact Sales for further details.

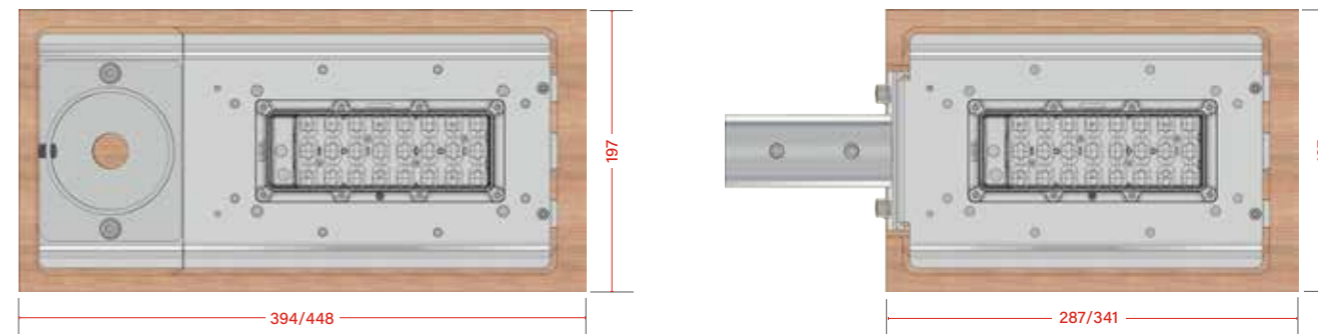

OAKEN 48

Dimensions displayed in millimetres (mm)

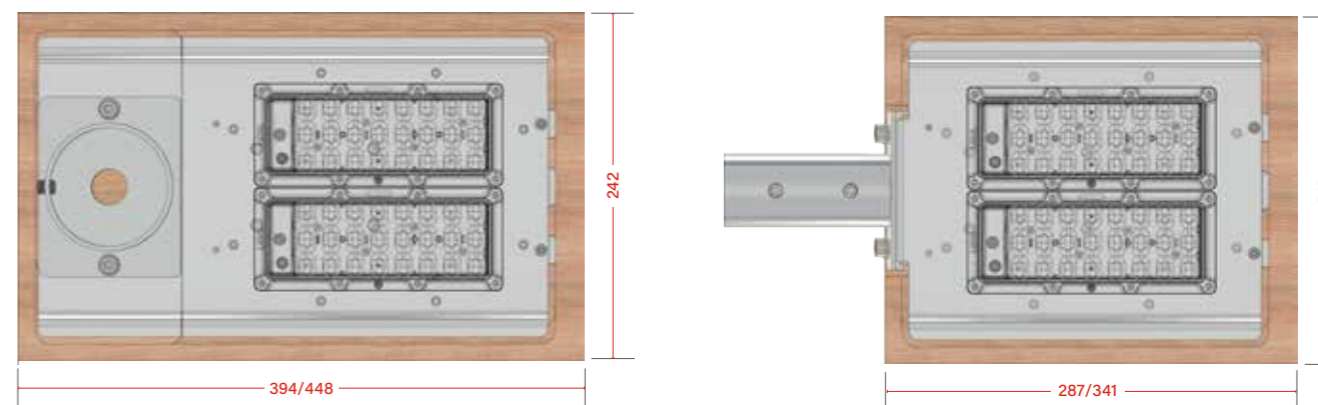

MOUNTING

Dimensions displayed in millimetres (mm)

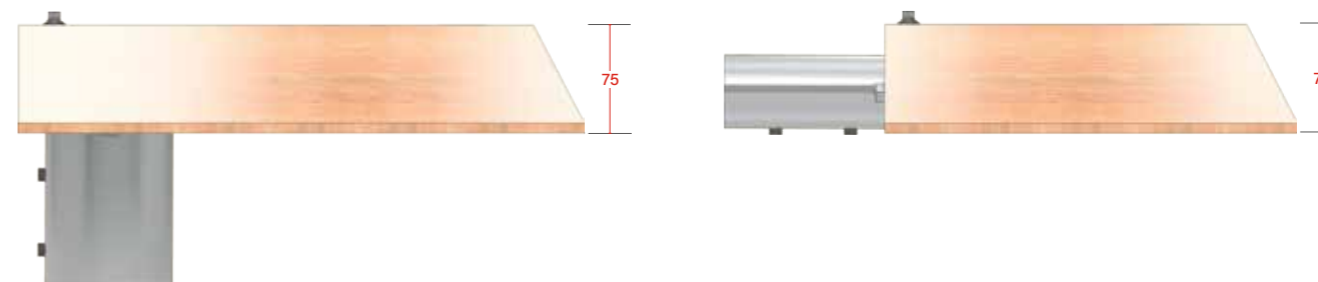

TRT OAKEN ORDER CODES

EXAMPLE OAK48 2 40 R2M 4K SE 7A1 N7 GD PN 752022 5000

1. Part Night available in up to 2 customisable settings, listed as Step 2 or Step 2+3 (Step 1 & Step 5 are fixed at 100% output)

STEP 1	STEP 2	STEP 3	STEP 4	STEP 5	STEP 6	STEP 7	STEP 8	STEP 9	STEP 10	STEP 11	STEP 12		
Select Product Variant	Generation	Select Power Level	Select Distribution	Select CCT	Select Adaptor & Orientation	Select Flying Lead	Controls	Vent Plug	Part Night ¹	Part Night step 2	Part Night step 3		
Mandatory Fields						Optional Extras							
OAK12 Standard Oaken Single 12 LED	2 = 2nd Release	5 up to 30 (in 1 watt steps)	GA2 = General Area 2 GA3 = General Area 3 GR1 = General Road 1 GR2 = General Road 2 GR5 = General Road 5 GR7 = General Road 7	4K = 4000K 3K = 3000K 27K = 2700K PCA = PC-Amber	SE = 42mm Side Entry PT = 76mm Post Top Entry	7L1 = 7m of 3-Core Arctic Low Copper 1.5mm ² Cable	LL = Lumi-LinQ N7 = 7 Pin NEMA socket ZT = Zhaga Book 18 socket, top with cap ZB = Zhaga Book 18 socket, bottom with cap	GD = Integrated Vent Plug	PN = Factory set part night dimming	752022 = eg: 75% from 20:00 until 22:00	5000 = eg: in addition to Part night Step 2, dim to 50% until 00:00		
OAK24 Standard Oaken Single 24 LED		5 up to 30 (in 1 watt steps)	A2M = Area 2 A3M = Area 3 R1M = Road 1 R2M = Road 2 R5M = Road 5 R7M = Road 7	4K = 4000K 3K = 3000K 27K = 2700K		9L1 = 9m of 3-Core Arctic Low Copper 1.5mm ² Cable						7A1 = 7m of 3-Core Arctic 1.5mm ² Cable	9A1 = 9m of 3-Core Arctic 1.5mm ² Cable
OAK48 Standard Oaken Twin 48 LED		30 up to 60 (in 1 watt steps)											

PowerSet NFC wattages are pre-set as below (other wattages can be set upon request).

Oaken 12 Standard	10W	14W	19W	23W	27W	30W	Oaken 24 Standard	10W	14W	19W	23W	27W	30W	Oaken 48 Standard	30W	35W	40W	45W	50W	55W	60W
-------------------	-----	-----	-----	-----	-----	-----	-------------------	-----	-----	-----	-----	-----	-----	-------------------	-----	-----	-----	-----	-----	-----	-----

GLOSSARY

Carbon Neutral:	Having or resulting in no addition of carbon dioxide to the atmosphere. Either by reducing and/or offsetting the amount of carbon dioxide emitted.
Embodied Carbon:	Refers to the total GHG emissions associated with the production, transportation, and disposal of building materials and construction processes, reflecting environmental impact throughout a product's lifecycle.
Greenhouse Gas (GHG):	Gases that trap heat in the Earth's atmosphere, contributing to global warming. Examples include carbon dioxide, methane and nitrous oxide.
ISO 14064-3:	An international standard for the quantification and reporting of greenhouse gas (GHG) emissions and removals.
ISO 14065:	An international standard which specifies the principles and requirements for bodies validating and verifying environmental information.
Net-Zero:	Having or resulting in no addition of carbon dioxide to the atmosphere. Either by reducing and/or offsetting the amount of greenhouse gases (GHGs) emitted.
PEFC:	PEFC (Programme for the Endorsement of Forest Certification) ensures sustainable forest management by verifying that wood and wood products come from responsibly managed forests, promoting environmental, social, and economic responsibility in forestry practices.
Scope 1 Emissions:	Direct GHG emissions from the activities of an organisation including fuel combustion on site, such as in gas boilers, and in its fleet of delivery and other company-owned vehicles.
Scope 2 Emissions:	Indirect GHG emissions resulting from purchased energy used by the company. These emissions are caused during the production of the electricity that is ultimately used by the organisation.
Scope 3 Emissions:	Indirect GHG emissions from activities of the company, from sources that it does not own or control e.g., its supply chain.
TM65:	TM65 stands for Technical Memorandum 65. A methodology for calculating embodied carbon in building services equipment.
TM66:	TM66 stands for Technical Memorandum 66. A rating system for lighting manufacturers to demonstrate their circular economy performance in a product. The highest score is 4.0.





TRT Lighting Ltd
Heming Point | Claybrook Drive | Washford Ind Est
Redditch | B98 0FH | United Kingdom
t +44 (0)1527 521162 e info@trtlighting.co.uk

www.trtlighting.co.uk

